

NA6O Portable Off-Center Fed Vertical Dipole

Aug 29, 2017

This portable antenna kit supports 40 through 10 m with any transceiver containing an ATU up to 100 W. It requires a 10 m pole from SOTA Beams for support. Being an off-center fed vertical dipole, no radials are required. As with any vertical, performance will be best over very good (highly-conductive) ground, as you might find at the beach.

Kit Contents

1. Matching Unit. Contains a 4:1 impedance transformer and high-impedance common-mode chokes. BNC connector for RF and banana jack binding posts for antenna connections. Also has a switch to select 1:1 impedance in case you want to use it for a nominally balanced and matched antenna such as a dipole.
2. Counterpoise loading inductor. Required for 30 and 40 m. Plugs into Matching Unit.
3. Tape measure counterpoise. Plugs into Matching Unit, allows simple repeatable tuning.
4. Three-segment wire, total 25 ft long. Hangs from the SOTA pole.
5. Velcro straps. For mounting SOTA pole to a fixed object and for keeping wire in place.

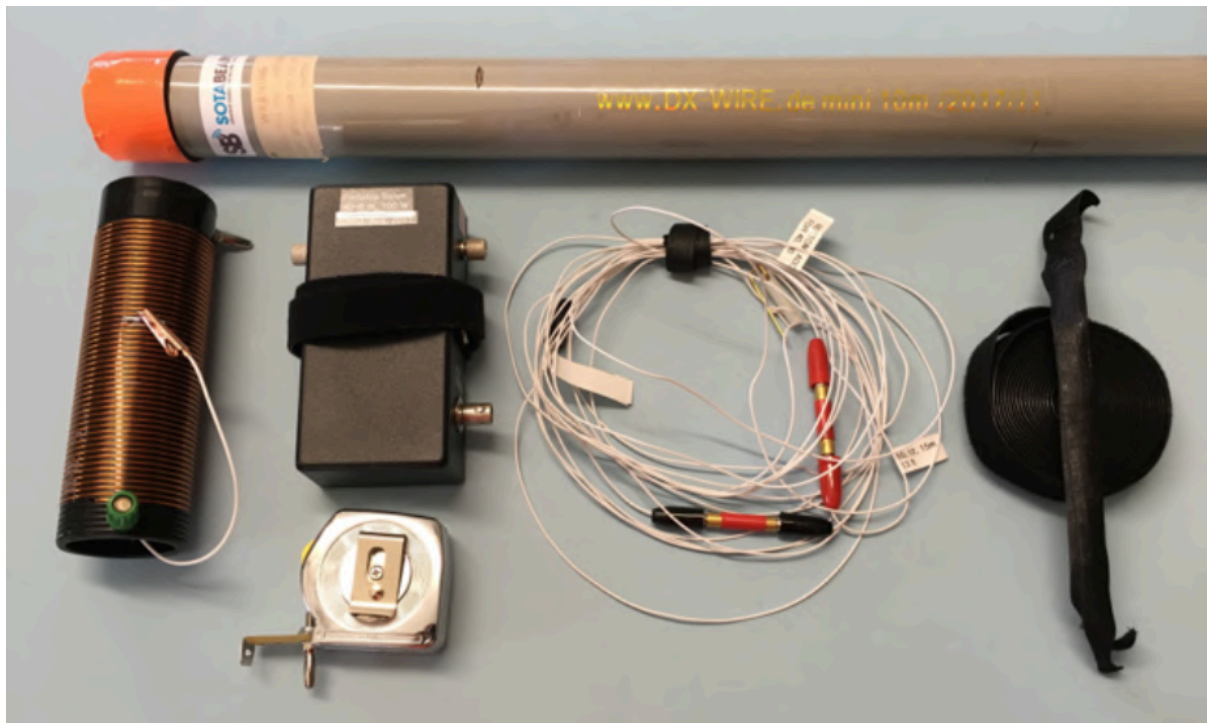

Setup

1. Attach the SOTA pole to something solid. Use the Velcro straps or any other means at hand to keep it vertical. You may guy the pole if desired (not described here).
2. Uncoil the wire on the ground and get rid of any tangles.
3. Uncap the SOTA pole and use the wire support clip to extract the tiny center (top) section. Hang the wire from the top section.
4. Begin extending the SOTA pole. When you get to one of the segment connectors, apply a Velcro strap to keep it from whipping around in the wind.

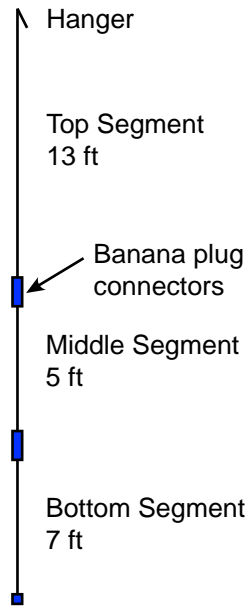

Depending upon your band selection, install the top, or the top plus the middle, or all three segments in series (see Table 1). Don't lose the small coupling sleeves for the banana plugs; leave them plugged into something when not in use.

5. Extend the SOTA pole to one segment short of the required height.
6. Attach the Matching Unit to the pole. Hold its back firmly against the pole and wrap the attached Velcro strap around it. The sticky back will keep it from sliding down.
7. Plug the vertical wire into the UP jack.
8. Plug the tape measure into the DOWN jack, unless you are running 30 or 40 m, in which you must first plug in the loading inductor, then plug the tape into that.
9. Connect your feedline.
10. Extend the SOTA pole until the matching unit is at least 6 feet above ground.
11. Try to route the feedline away from the vertical pole. A 45-degree angle is ideal.



Tuning

Nominal tuning settings are listed in Table 1. Note that 30 m requires you to connect the clip lead to the tap on the loading inductor. ***Make sure the Matching Unit is always set to 4:1.***

1. Set the tape measure to the recommended length.
2. If you have an antenna analyzer, connect it via a short cable and measure SWR, or use your rig's SWR meter.
3. Adjust the tape measure length for best match. Once you have a satisfactory length, secure the tape to the pole with Velcro to keep it from swinging in the wind.

NOTE: Do not let the tape touch the ground or any other conductor. This will drastically change tuning and may also put the lossy Earth conductivity in series with the counterpoise, reducing efficiency.

Table 1. Recommended Tuning

Band	Vertical Segments	Loading Coil	Tape length (in.)
10	Top	No	28
12	Top	No	57
15	Top, Mid	No	24
17	Top, Mid	No	44
20	Top, Mid, Bot	No	53
30	Top, Mid, Bot	Clip to tap	48
40	Top, Mid, Bot	Full length	36

It is also possible to achieve a good match with other sets of vertical segments. Those listed here were measured via RBN reports as having optimal performance.

Other Uses

The Matching Unit can be set to 1:1 mode and used as a balun for regular dipoles. It can also be used in 4:1 mode with off-center fed dipoles on all bands 80 through 6 m.

The chokes are extremely effective down to 3 MHz, so you can use it on 80 m with any full-sized antenna.

The transformer and chokes are usable on 6 m as well, with low loss.

Maintenance

If a wire comes out of a banana plug, simply strip it, slide it through the angled hole in the plug, and firmly tighten the handle. You can also connect broken wires by twisting them together or by using the binding posts. Supplied wire is 22 AWG but other sizes are fine.

If the sticky back on the Matching Unit gets too dirty, it won't stick to the SOTA pole. Clean it with warm water. If it needs replacement, find a generic sticky dashboard mat designed for keeping your phone on the dash, and stick that to the back.

Tip: Insert a round foam plug about 1/4 inch thick in the bottom cover of your SOTA pole to protect the fiberglass sticks in case they are dropped.

Avoid dropping BNC connectors in the dirt!!!

Specifications

Bands: 40, 30, 20, 17, 15, 12, 10 m.

SWR: < 3:1 worst-case (50 ohms) using tuning settings from Table 1.

Power: 100 W continuous.

Matching Unit efficiency: >95%

Common-mode choke impedance: > 5k 3.5-8 MHz. > 2k 10-50 MHz

Construction

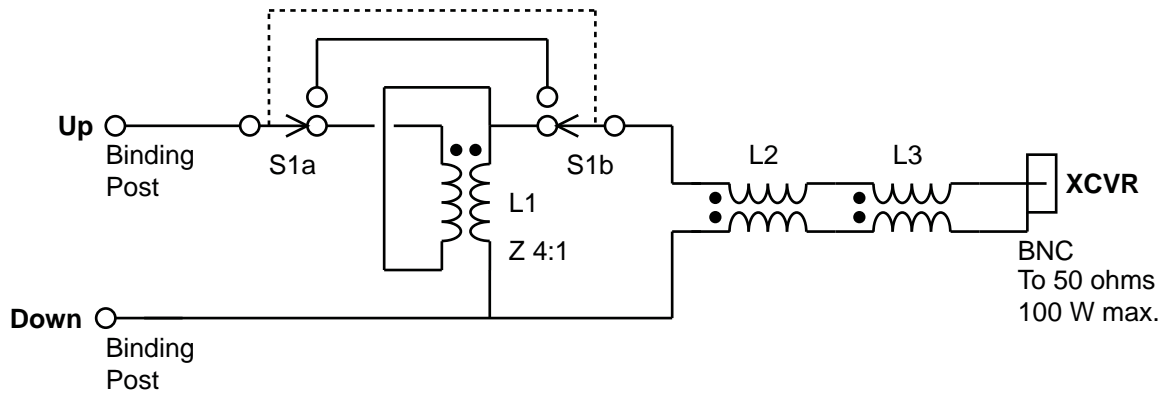

L1 4:1 impedance transformer. 12T #23 bifilar on FT114A-61.

L2 Choke. 12T RG-174 on FT140-43.

L3 Choke. 16T RG-174 on FT140-43.

Binding posts: Cinch 111-2223-001.

S1: Small DPDT slide switch or toggle.

Enclosure: Bud CU-745.

S1 allows bypassing of 4:1 transformer for use on nominally 50 ohm antennas.

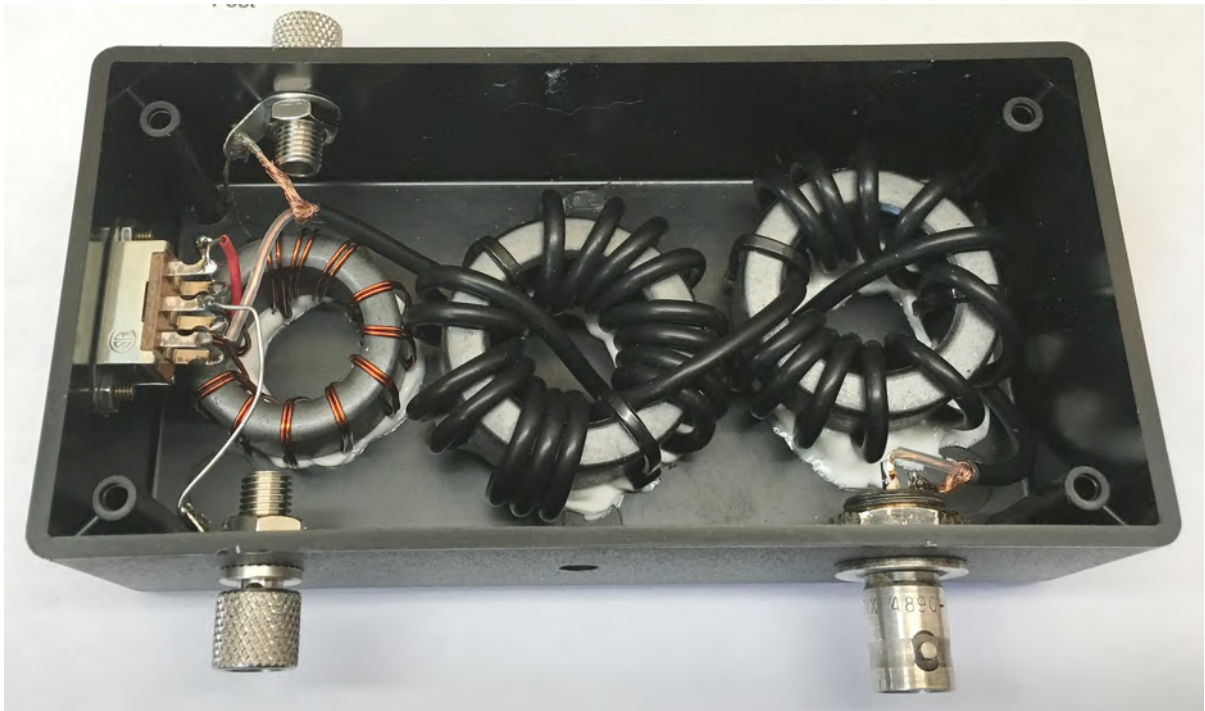

Loading Coil (for 30 and 40 m)

48 turns, 10 turns per inch #18 AWG on 1.5-inch PVC or ABS pipe (1.9 in. OD)

About 36 μH total. Shorted at 30 turns (leaving 18 turns active) for 30 m. None of these values or dimensions are critical.

