

Homebrew Line Impedance Stabilization Network (LISN) for EMI Testing

Gary W. Johnson, NA6O

Feb 2019

Introduction

Testing of electronic devices for compliance with FCC Part 15 or European CISPR conducted electromagnetic noise emissions requires that the device under test be powered via a Line Impedance Stabilization Network (LISN). My need for a LISN was driven by an interest in characterizing noise from all kinds of switching power supplies (especially LED lights) that interfere with my amateur radio reception, primarily below 30 MHz. If you are assembling a formal compliance testing lab, you would of course buy a commercial LISN, but the price is typically well out of reach for the hobbyist. After studying some published designs, I built my own for about \$200, and the performance is excellent.

What is a LISN?

The LISN is a basically a lowpass filter network connected in series with the AC line that performs the following functions:

1. Provides a constant 50 ohm source impedance from each line to ground for the device under test (DUT), over a wide RF bandwidth.
2. Isolates the DUT from noise on the AC mains so as not to interfere with sensitive RFI measurements.
3. Provides a (safe) 50-ohm compatible sample of the noise voltage on each line feeding the DUT.

A simplified LISN circuit appears in Fig. 1. Depending upon the application, they can be designed for various bandwidths, AC or DC operation, and various voltage and current ratings. C1 is typically several microfarads and serves as an input RF bypass. C2 couples noise from the DUT (the quantity to be measured) to the EMI receiver and also connects the DUT to the required 50-ohm terminator. The inductor provides lowpass filtering of noise from the AC mains and a high impedance between the DUT and the mains. 50 μ H is a standard value and provides reliable data down to about 150 kHz, regardless of the AC mains impedance. R1 is a small damping resistance to prevent resonance between C1 and the inductor. An identical circuit is required for each phase.

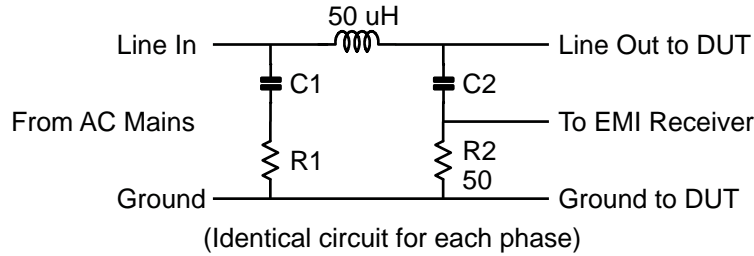

Figure 1. Simplified LISN circuit.

Customization

My noise-hunting interests are from 1 to 150 MHz, so I chose components that would provide reliable response over that range. In particular, SMT inductors are used to reduce problems with self-resonance. An additional 250 uH inductor was added at the AC mains input to provide another lowpass filter pole. Having no plans to test high-power equipment, I was able to use smaller inductors rated at about 9 Amps. Initial design suggestions came from an online group [Ref 1].

Signal conditioning was added to the EMI receiver output, consisting of an attenuator, highpass filter, and limiters. This circuit was basically copied from an old HP 11947A Transient Limiter. It protects the downstream instruments from over-voltage, further reduces the 60 Hz amplitude, and provides a good 50 ohm match. Using SMT parts, it's useful to over 200 MHz.

Common-Mode Current Transformer

A big shortcoming of the national standards for EMI is that they only measure *normal-mode* noise, that is, from line to ground. While that is a one indicator of the noise generating properties of a device, *common-mode* current is actually more relevant when it comes to radio interference, especially in the HF bands. Even more important, *all three conductors* to the DUT (hot, neutral, *and* ground) must be considered as likely RF radiators. Shunting noise from hot or neutral to ground simply makes the grounding conductor yet another antenna element to radiate noise.

For that reason, I included a wideband current transformer (CT) at the output with the three lines passing through it. (Note that the body of the DUT outlet must be isolated from the chassis, and grounded only via a wire through the CT.) Commercial wideband CTs for EMI measurements are available from companies such as Fischer Custom Communications. However, at around \$2000 those are way beyond my budget. But they're not hard to make with a ferrite toroid.

A bit of study and testing went into this CT design. Variables include the size and material of the ferrite core, and the number of turns. My requirements were high sensitivity and a bandwidth greater than 1 to 150 MHz. I finally settled on a 1.4-inch OD mix 43 core (FT140-43) with 5 turns and a 50-ohm terminator. This provided a response of 4.8 V/A (commonly known as Z_T , since the units are Ohms) and a -3 dB bandwidth of

0.22 to 172 MHz. Figure 2 shows the frequency response, measured with a vector network analyzer and a calibration fixture that I replicated from the commercial units.

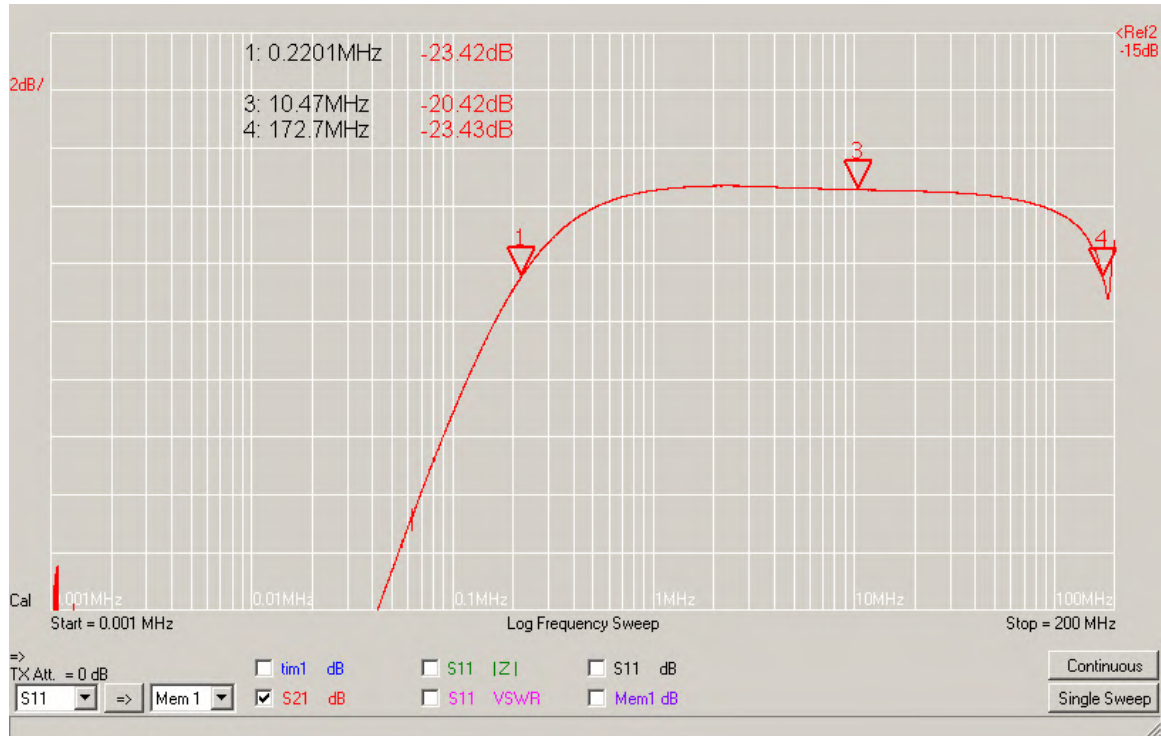

Figure 2. Frequency response of the wideband current transformer.

I also discovered that common-mode noise on the cable from the CT would creep into the measuring equipment, so a common-mode choke was added on the RG-174 coax inside the chassis (Fig. 3). An isolated BNC connector goes to the outside world; using a grounded one would defeat the common-mode choke.



Figure 3. Wideband current transformer and common-mode choke. The 50-ohm terminating resistor is covered by tape.

The Build

A complete model was evaluated in LTSpice, focusing on the effects of self-resonance in the inductors and capacitors. Predicted performance easily met my requirements.

A circuit board was laid out in CircuitMaker and the design is available online [Ref. 2]. It's double-sided with a full ground plane on the back and measures 4 by 5.5 inches. Wide traces are used for the expected high currents and 2 oz. copper was specified for fabrication. Wide clearances between conductors and ground pours were also used in order to avoid high-voltage transient breakdown. I had it fabricated by a Chinese service that provides quick turnaround at astonishingly low prices [Ref. 3].

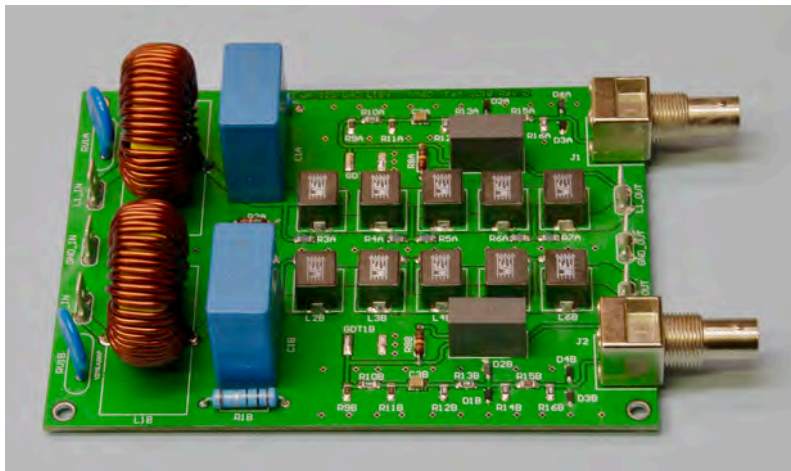

Figure 4. The completed circuit board.

Note that any capacitors connected directly to the AC line must be *safety rated*. Known as *X* and *Y* capacitors, they are certified not to fail catastrophically when exposed to expected high-voltage transients. Metal oxide varistors at the line input will help to reduce such transients.

Everything was packaged in a commercial steel enclosure; some paint had to be ground off of the internal surfaces to obtain a reasonably good RF-tight connection to the covers. For added EMI rejection, a filtered power inlet module was selected. It also has fuses and a switch (Figs. 5, 6).

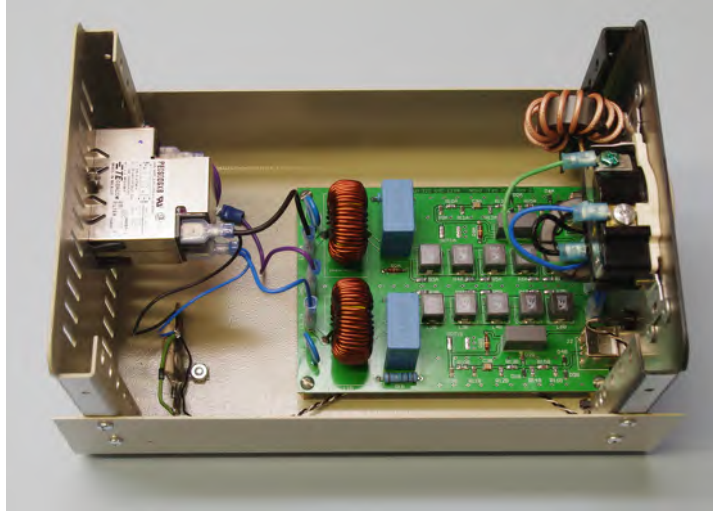

Figure 5. Interior of the chassis.



Figure 6. Front view.

Performance

First, an important operational note regarding all LISN circuits: The presence of large capacitance from line to ground will trip a GFCI. You can use a non-GFCI circuit, or even better, use an isolation transformer. The latter solution is recommended practice in commercial laboratory work and also provides an additional layer of safety.

Detailed measurements were made with a vector network analyzer (DG8SAQ VNWA 3E) [Ref. 4]. In Fig. 7, the S11 trace shows that the line output exhibits a return loss better than 10 dB from 0.25 to 100 MHz. High-frequency degradation is due to a 29 MHz self-resonance in the 50 uH inductor chain and was predicted in simulation. The S21 trace shows that isolation from line in to line out is greater than 40 dB from 0.11 to 60 MHz. Figure 8 shows that the monitor output has a wide, flat attenuation of 9.3 dB

from 77 kHz to beyond 200 MHz. In all cases, data for the second line was identical within measurement uncertainty. This performance easily meets my needs and is at least as good as any commercial LISN of the same class.

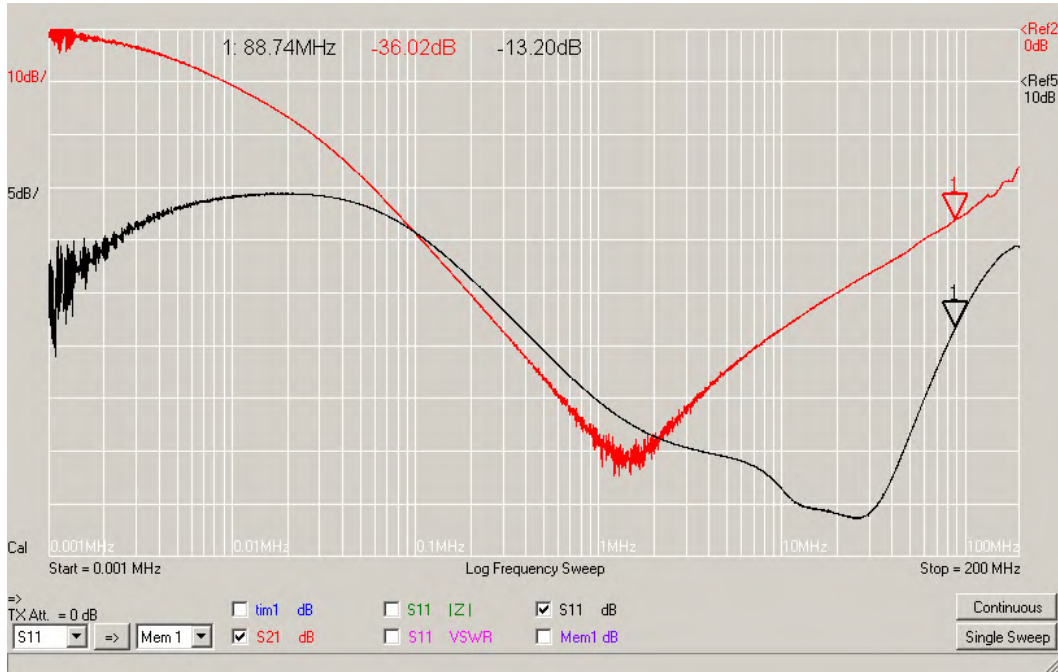

Figure 7. Red: S21 (transmission) from line 1 out to line 1 in. Black: S11 (return loss) of line 1 out.

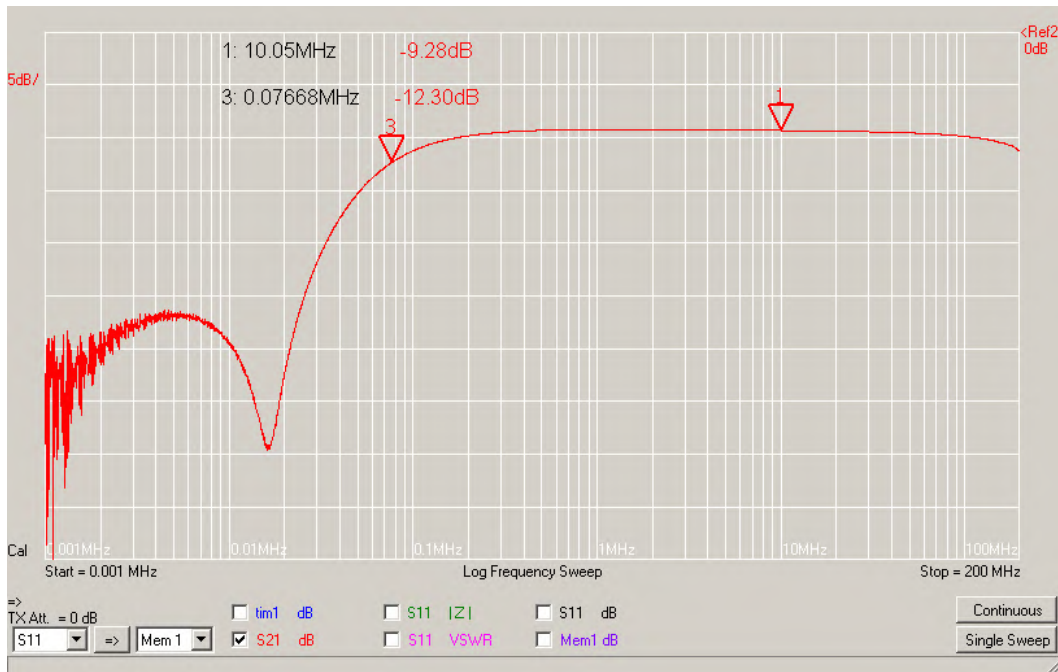

Figure 8. Transmission from line 1 out to monitor 1 out.

Practical Results

Not all switching power supplies are horribly noisy, so the signals coming out of the LISN can sometimes be at a fairly low level, especially if you're examining them with an oscilloscope. Also, my spectrum analyzer (HP 8560A) does not have a preamp. So a handy add-on is a wideband RF preamp based on cheap MMIC amplifiers. The one I have uses a Mini-Circuits MAR-6 and has a low noise figure (2.3 dB), 20 dB of gain, and a maximum output voltage before compression of about 0.8 V p-p. The very noisiest devices can drive this into clipping, however, so watch out for that.

Figure 9 shows common-mode spectra for some actual test articles. The bottom trace is an incandescent bulb, and shows the noise floor of the system including the preamp. Since everything is calibrated, the values are scaled to Amps. Many signals from the FM broadcast band are leaking into the measurement. This is a very common problem in my lab and the signals are entirely picked up on the DUT cable, even though it is only 6 inches long. That's why commercial EMC labs are built inside screen rooms. For reference, the flat noise floor is about -105 dBm at the connector to the current transformer.

The middle trace is what I have found to be a quiet LED bulb that does not cause any detectable interference in the HF bands. Its normal-mode voltage measurements are also way below FCC Part 15 limits.

The top trace is a horrible LED light fixture that, amazingly, does squeak by the FCC limits but obliterates several of the HF bands and will even interfere with 144 MHz communications and FM radios.

Having this reliable LISN is going to help me characterize all kinds of noise-generating devices as well as various remediation techniques such as common-mode chokes.

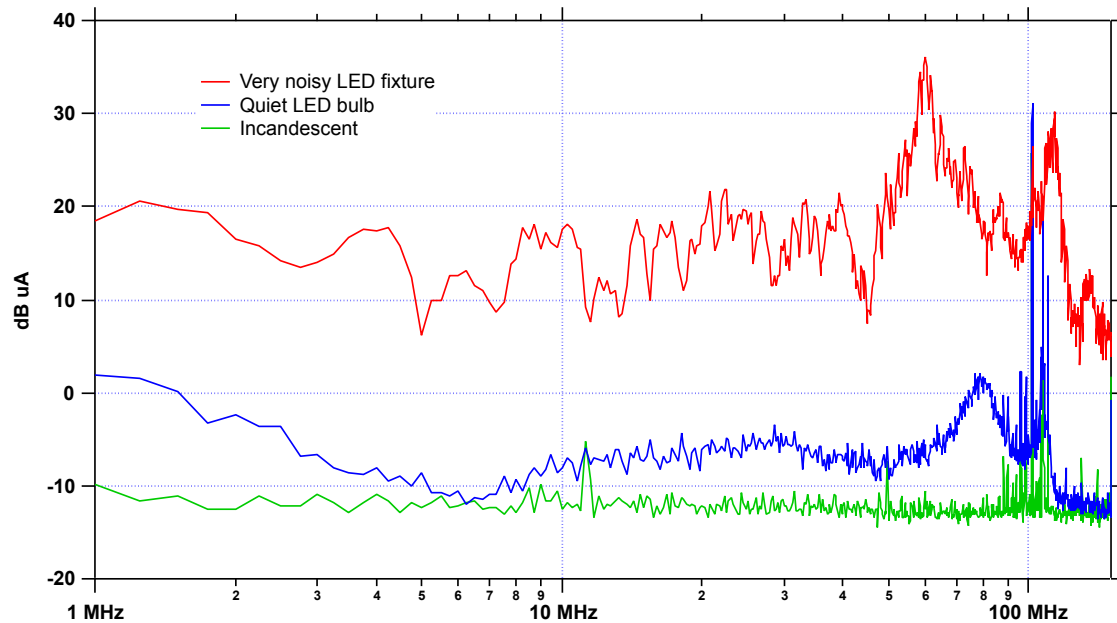
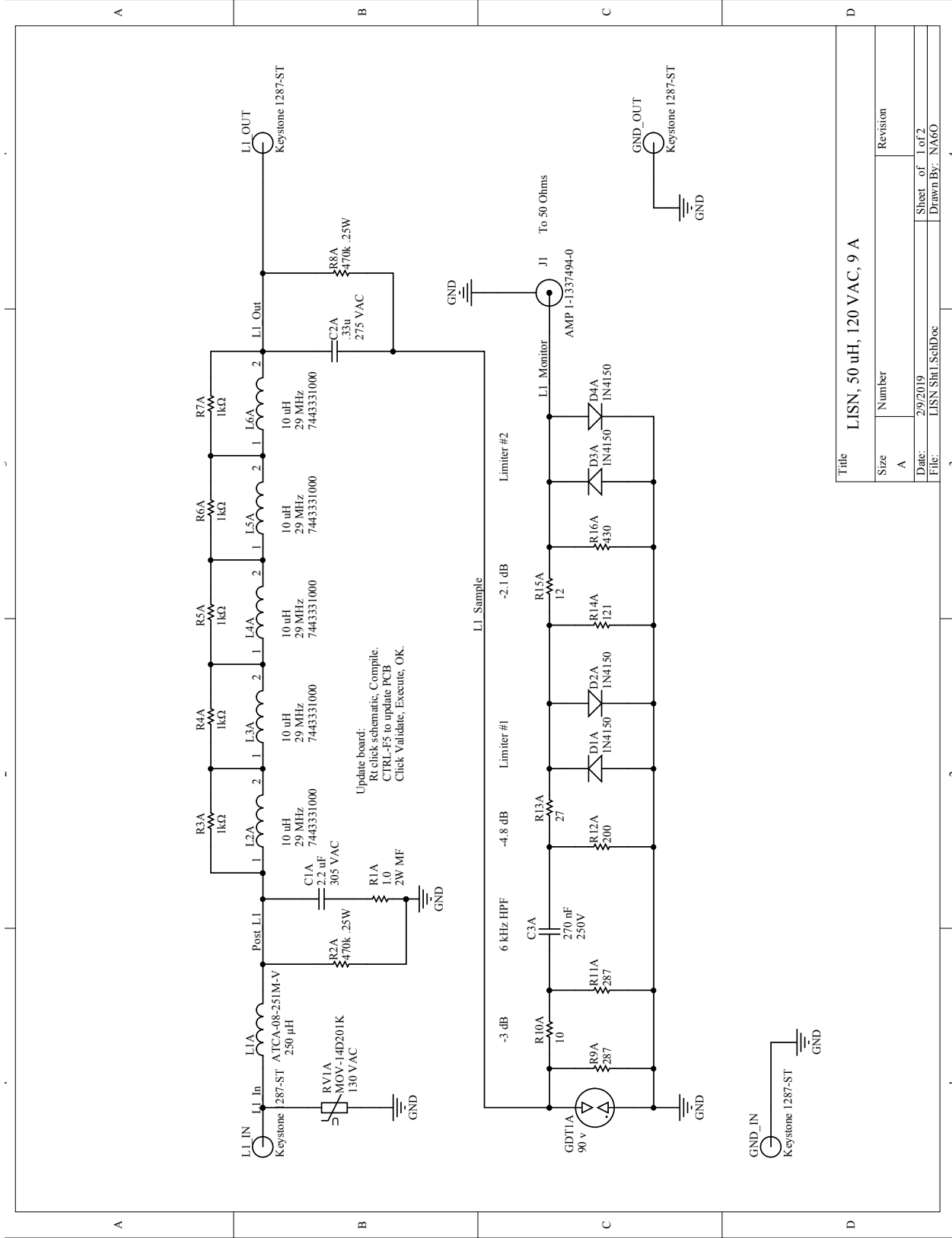
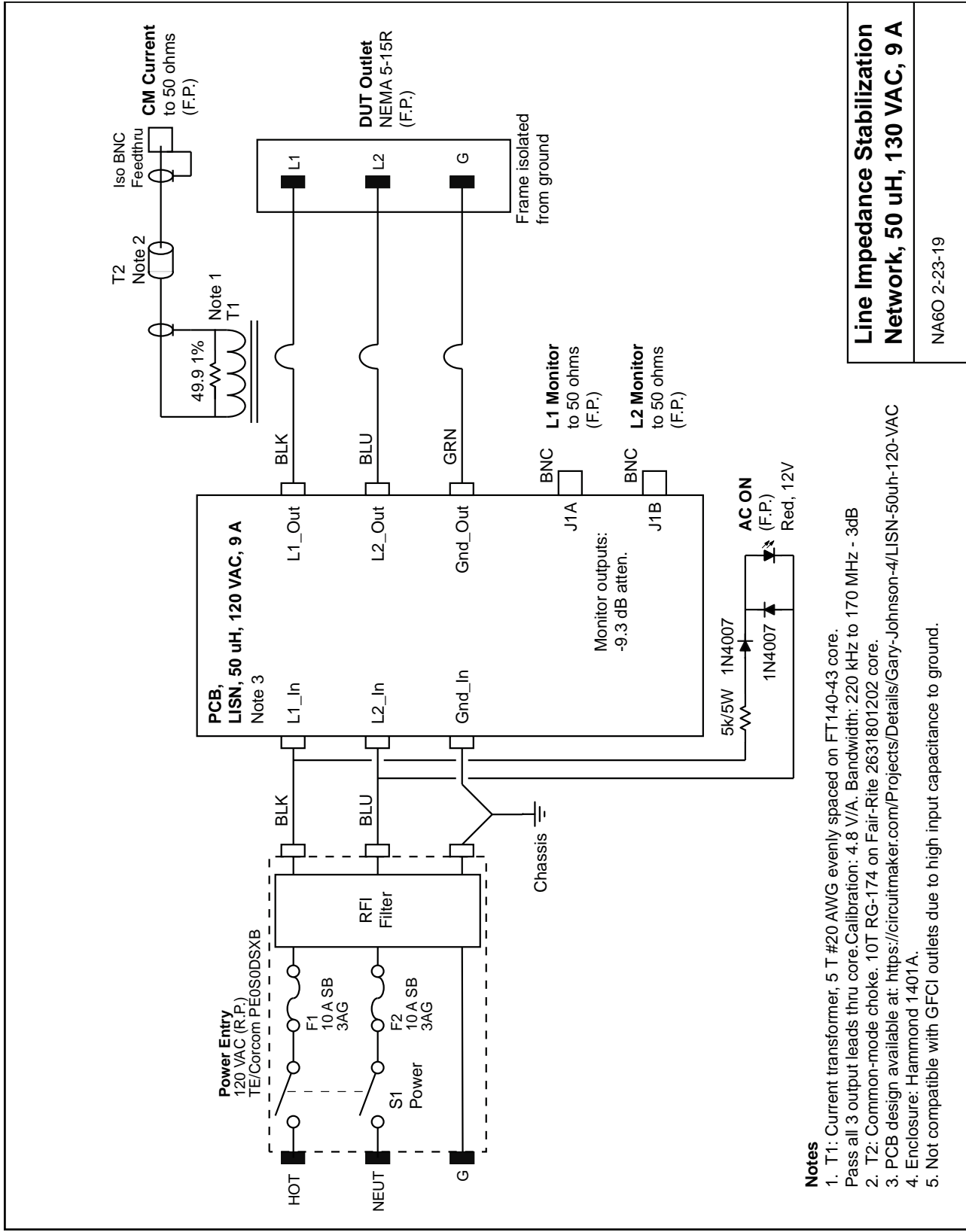

Figure 9. Actual common-mode current spectra for an incandescent bulb, a quiet LED bulb, and a noisy LED light fixture. FM broadcast band interference is always there.

References

1. EEVblog Electronics Community Forum, topic: *5uH LISN for Spectrum Analyzer EMC/EMI work*. <https://www.eevblog.com/forum/projects/5uh-lisn-for-spectrum-analyzer-emcemi-work/msg641108/> - msg641108
2. CircuitMaker is a free, community-based schematic capture and PCB layout tool sponsored by Altium. Design of this project's board is open source and available here: <https://circuitmaker.com/Projects/Details/Gary-Johnson-4/LISN-50uh-120-VAC>
3. JLCPCB (Shenzhen JLC Electronics Co., Ltd.) PC board fabrication. <https://jlcpcb.com/>
4. DG8SAQ VNWA. <https://www.sdr-kits.net/introducing-DG8SAQ-VNWA3>





Line Impedance Stabilization Network, 50 uH, 130 VAC, 9 A

NA60 2-23-19